

Close Coupled Turbine Pumps

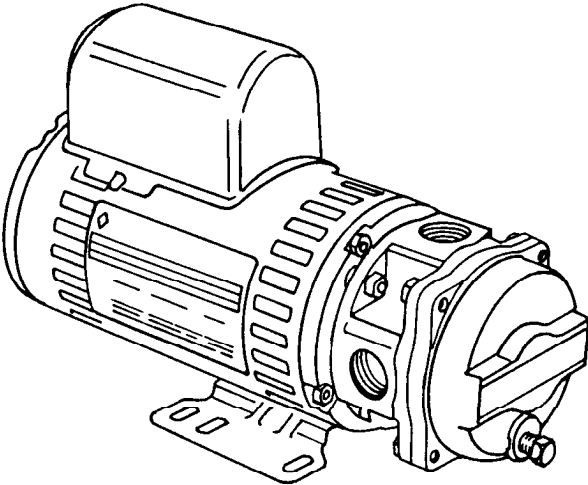

APPLICATIONS

- Carpet Cleaning Machines
- Small Steam Generators
- Solar Heating Systems
- Booster Pump
- Injector Venturi Operation
- Cleaning and Flushing
- Low Flow Circulating
- Spray Nozzles
- Liquid Transfer
- Coolant Pump
- Aeration

BURKS exclusive, unique regenerative type turbine pumps are designed to handle clear water and many other nonabrasive, lower viscosity liquids on high pressure/low capacity applications with the greatest possible efficiency.

60 HZ - PERFORMANCE										
Catalog Number		HP	PSI (kpa) Feet (m)	TOTAL HEAD						
115V	230V				10.8 (74) 25 (7.6)	21.6 (149) 50 (15.2)	32.5 (224) 75 (22.8)	43.3 (299) 100 (30.4)	54.1 (373) 125 (38.1)	64.9 (447) 150 (45.7)
CAPACITY IN GPM (LPS)										
A3CR6M	3CR6M	1/3		4.3 (0.23)	3.9 (0.24)	3.6 (0.23)	3.4 (0.21)	3.2 (0.2)	3.0 (0.19)	2.9 (0.18)
	3CR6M-DP	1/3		4.3 (0.23)	3.9 (0.24)	3.6 (0.23)	3.4 (0.21)	3.2 (0.2)		

3450
RPM

50 HZ - PERFORMANCE										
Catalog Number		HP	PSI (kpa) Feet (m)	TOTAL HEAD						
	220V				10.4 (72) 24 (7.3)	20.8 (143) 48 (14.6)	37.7 (260) 87 (26.5)	49.4 (341) 114 (34.7)	55.4 (382) 128 (39.0)	68.4 (472) 158 (48.2)
CAPACITY IN GPM (LPS)										
	L3CR6M	1/3		3.6 (0.23)	3.2 (0.20)	2.8 (0.18)	2.6 (0.16)	2.5 (0.16)	2.3 (0.15)	2.1 (0.13)
	L3CR6M-DP	1/3		3.6 (0.23)	3.2 (0.20)	2.8 (0.18)	2.6 (0.16)	2.5 (0.16)	2.3 (0.15)	2.1 (0.13)

2900
RPM

Close Coupled Turbine Pumps

- Compact Size-Ideal for OEM Applications
- All Bronze Construction with Monel Impeller Blades
- Carbon/Ceramic Shaft Seal for Temperatures to 225°F (107°C)
- 316 Stainless Steel Shaft
- Close Coupled Design - No coupling or alignment problems
- Motors have ball/ball bearing construction and open ventilated enclosure. Standard motor is NOT drip-proof. Rated for continuous duty operation at all ratings shown. Drip-Proof motor is available as option for 230 volt.
- Capacitor Start motors have built-in automatic overload protection
- Furnished with UL Recognized motor lead
- Field adjustable impeller for extended service life
- Easy to service
- Every pump factory tested

MAXIMUM OPERATING CONDITIONS	
TEMPERATURE (For Standard Buna-N Seal)	225°F (107°C)
INLET PRESSURE	50 PSI (344kPa)
CASING WORKING PRESSURE	150 PSI (1034kPa)
VISCOSITY	200 SSU

MATERIALS OF CONSTRUCTION	
PART	ALL BRONZE
Frame/Raceway	Bronze
Impeller	Bronze (Monel Blades)
Shaft	#316 Stainless
Front Cover	Bronze
Shaft Seal	Carbon-Ceramic SS - Buna-N

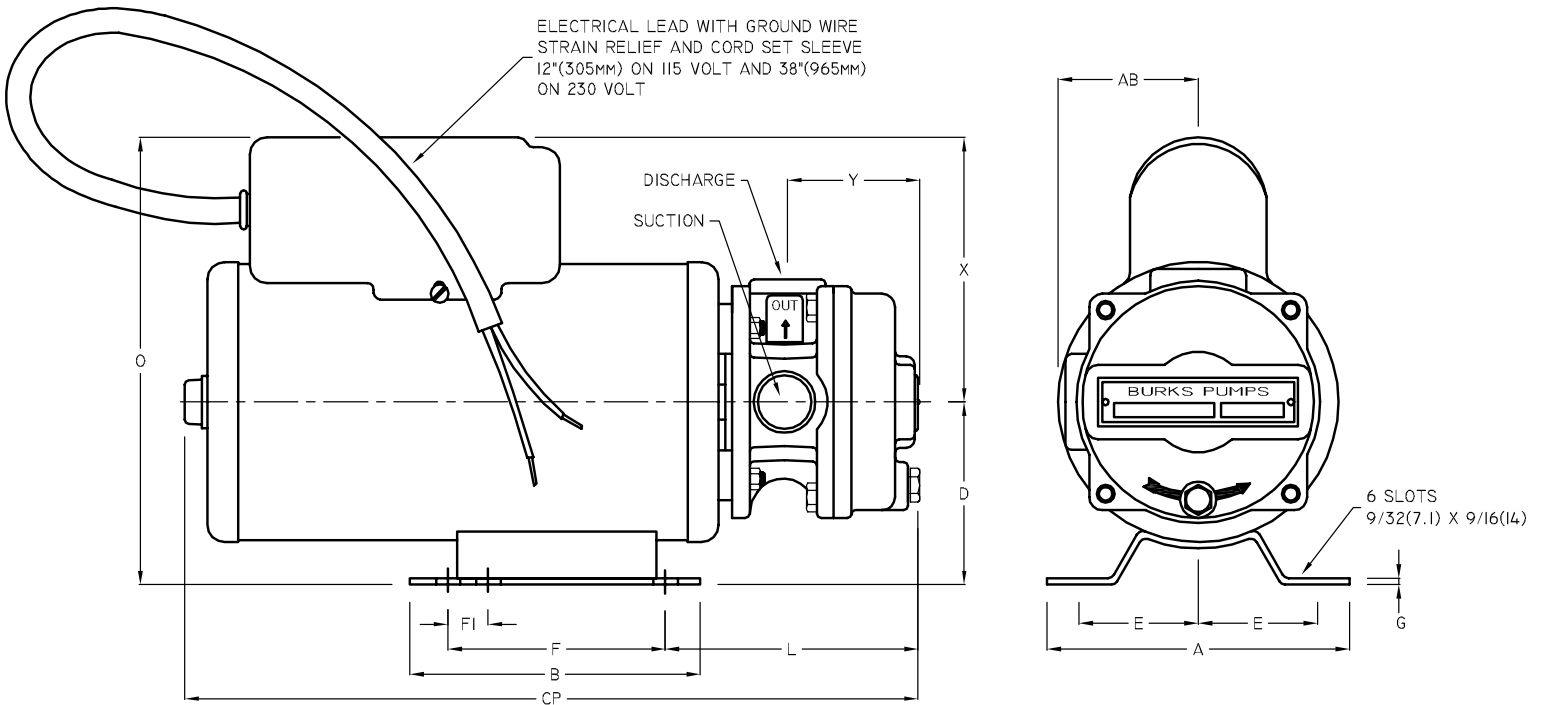

TAPPINGS			DIMENSIONS IN INCHES (mm)												
DISC. NPT	SUCT. NPT	Motor Frame	A	AB	B	CP*	D	E	F	F1	G	L	O*	X	Y
1/2"	1/2"	36	4 (102)	1 7/8 (48)	3/4 (83)	10 1/2 (267)	2 1/4 (57)	1 1/2 (38)	2 1/2 (64)	5/8 (16)	1/16 (1.6)	3 5/8 (92)	6 1/4 (159)	1 3/4 (44)	2 (51)

(*) Approximate maximum dimension

A strainer, approximately 20 mesh, should be installed on the suction side of the pump to prevent chips, scale or hard foreign particales from entering the pump and damaging the raceway and impeller.

Close Coupled Turbine Pumps

