

Base Mounted Turbine Pumps

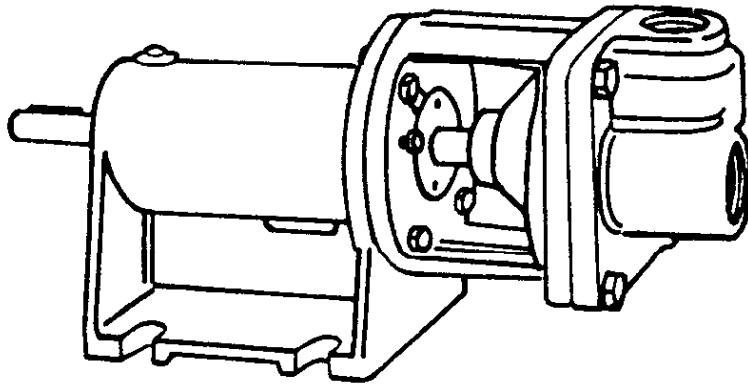

4ET - 1725 RPM - 60Hz.
ET - 3450 RPM - 60Hz.
 (See Individual curves for symbol number)

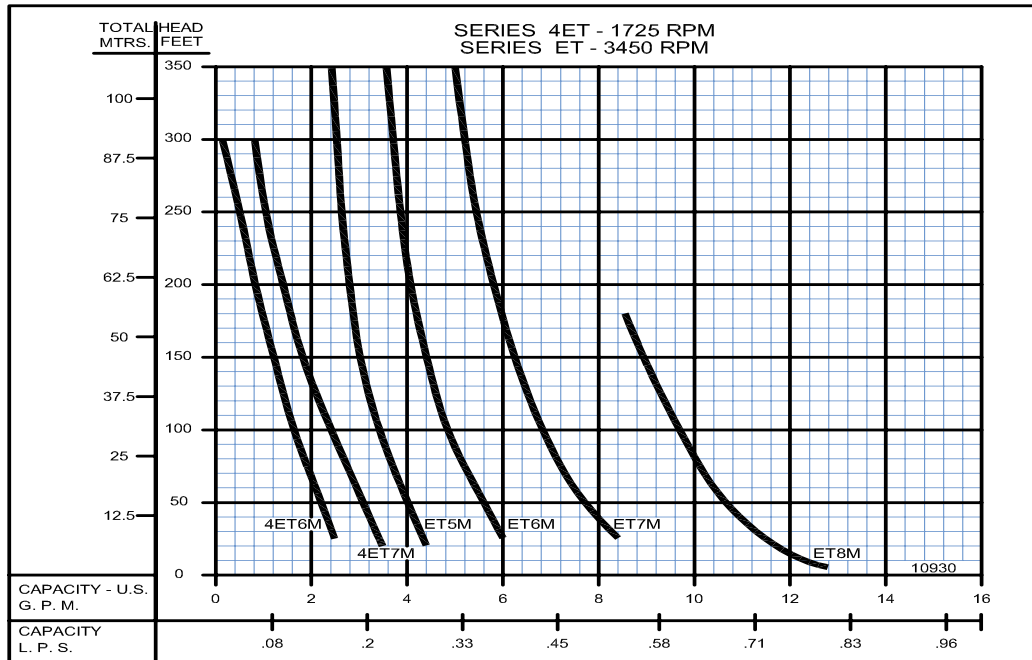

ET - 2900 RPM - 50Hz.
 (See Individual curves for symbol number)

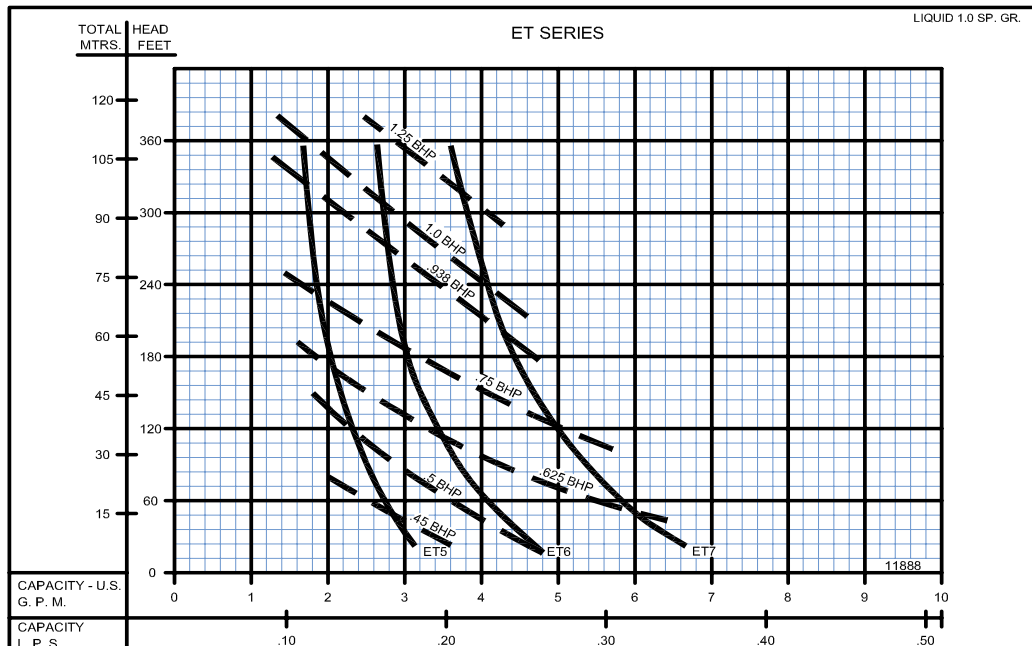

Base Mounted Turbine Pumps

1750 RPM

60Hz - PERFORMANCE AND SELECTION CHART																			
Capacity in GPM (LPS) at Total Head in Feet (m) or Pressure Shown																			
Catalog Number	PSI (kpa)	8.6 (59)	13 (89)	17.2 (118)	21.5 (148)	26 (179)	34.5 (237)	43.3 (298)	54.1 (373)	64.9 (447)	75.8 (522)	86.6 (597)	97.4 (671)	108.3 (746)	119.1 (821)	130 (896)	140.1 (965)	151.8 (1045)	
	Feet (m)	20 (6)	30 (9)	40 (12)	50 (15)	60 (18)	80 (24)	100 (30)	125 (38)	150 (45)	175 (53)	200 (60)	225 (68)	250 (76)	275 (83)	300 (91)	325 (99)	350 (106)	
ET5M	GPM (LPS)	1.9 (.11)	1.7 (.10)	1.6 (.10)	1.5 (.09)	1.4 (.08)	1.1 (.06)	1.0 (.06)	.80 (.05)	.60 (.03)	.40 (.02)	.30 (.01)	.20 (.01)						
	BHP	.10	.10	.10	.10	.10	.10	.10	.11	.13	.15	.17	.20						
	Motor Size	1/4 HP																	
ET6M	GPM (LPS)	2.4 (.15)	2.3 (.14)	2.2 (.13)	2.0 (.12)	1.9 (.11)	1.7 (.10)	1.6 (.10)	1.4 (.08)	1.2 (.07)	1.0 (.06)	.80 (.05)	.60 (.03)	.50 (.03)	.40 (.02)	.30 (.01)			
	BHP	.10	.10	.10	.10	.10	.10	.12	.17	.20	.23	.28	.30	.35	.40	.42			
	Motor Size	1/4 HP											1/3 HP						
ET7M	GPM (LPS)	3.4 (.21)	3.3 (.20)	3.1 (.19)	2.9 (.18)	2.8 (.17)	2.5 (.15)	2.3 (.14)	2.1 (.13)	1.8 (.11)	1.6 (.10)	1.4 (.08)	1.2 (.07)	1.0 (.06)	.85 (.05)	.70 (.04)			
	BHP	.10	.10	.10	.10	.13	.15	.18	.20	.23	.28	.30	.33	.36	.40	.47			
	Motor Size	1/4 HP											1/3 HP		1/2 HP				

3450 RPM

60Hz - PERFORMANCE AND SELECTION CHART																			
Capacity in GPM (LPS) at Total Head in Feet (m) or Pressure Shown																			
Catalog Number	PSI (kpa)	8.6 (59)	13 (89)	17.2 (118)	21.5 (148)	26 (179)	34.5 (237)	43.3 (298)	54.1 (373)	64.9 (447)	75.8 (522)	86.6 (597)	97.4 (671)	108.3 (746)	119.1 (821)	130 (896)	140.1 (965)	151.8 (1045)	
	Feet (m)	20 (6)	30 (9)	40 (12)	50 (15)	60 (18)	80 (24)	100 (30)	125 (38)	150 (45)	175 (53)	200 (60)	225 (68)	250 (76)	275 (83)	300 (91)	325 (99)	350 (106)	
ET5M	GPM (LPS)	4.2 (.26)	4.1 (.25)	4.0 (.25)	3.9 (.24)	3.8 (.23)	3.6 (.22)	3.4 (.21)	3.2 (.20)	3.0 (.18)	2.9 (.18)	2.8 (.17)	2.7 (.17)	2.6 (.16)	2.6 (.16)	2.5 (.15)	2.4 (.15)	2.4 (.15)	
	BHP	.20	.21	.25	.27	.29	.30	.33	.37	.39	.42	.47	.50	.56	.61	.66	.70	.78	
	Motor Size	1/3 HP										1/2 HP				3/4 HP			
ET6M	GPM (LPS)	6.0 (.37)	5.9 (.37)	5.7 (.35)	5.5 (.34)	5.3 (.33)	5.1 (.32)	4.8 (.30)	4.6 (.29)	4.4 (.27)	4.3 (.27)	4.2 (.26)	4.0 (.25)	3.9 (.24)	3.8 (.23)	3.7 (.23)	3.7 (.23)	3.6 (.22)	
	BHP	.28	.28	.285	.29	.30	.32	.38	.41	.48	.51	.57	.60	.65	.70	.72	.81	.88	
	Motor Size	1/3 HP							1/2 HP				3/4 HP						
ET7M	GPM (LPS)	8.3 (.52)	8.0 (.50)	7.8 (.49)	7.6 (.47)	7.4 (.46)	7.1 (.44)	6.8 (.42)	6.5 (.41)	6.2 (.39)	6.0 (.37)	5.8 (.36)	5.5 (.34)	5.5 (.34)	5.3 (.33)	5.2 (.32)	5.1 (.32)	5.0 (.31)	
	BHP	.32	.32	.36	.40	.41	.46	.52	.58	.65	.70	.76	.83	.89	.96	1.04	1.13	1.2	
	Motor Size	1/3 HP					1/2 HP			3/4 HP				1 HP					
ET8M	GPM (LPS)	11.7 (.73)	11.3 (.71)	11.0 (.69)	10.8 (.68)	10.5 (.66)	10.1 (.63)	9.7 (.61)	9.3 (.58)	8.9 (.56)	8.5 (.53)								
	BHP	.45	.50	.53	.57	.60	.70	.78	.88	.97	1.1								
	Motor Size	1/2 HP					3/4 HP			1 HP									

NOTE: When pumping hot water over 180°F (82.2°C), check the NPSH available in the pumping system against the required pump NPSH shown on pump performance curves. Available NPSH must be greater than required NPSH.

Base Mounted Turbine Pumps

50Hz - PERFORMANCE AND SELECTION CHART																				
Capacity in GPM (LPS) at Total Head in Feet (m) or Pressure Shown																				
Catalog Number	PSI (kpa)	8.6 (59)	13 (89)	17.2 (118)	21.5 (148)	26 (179)	34.5 (237)	43.3 (298)	54.1 (373)	64.9 (447)	75.8 (522)	86.6 (597)	97.4 (671)	108.3 (746)	119.1 (821)	130 (896)	140.1 (965)	151.8 (1045)		
	Feet (m)	20 (6)	30 (9)	40 (12)	50 (15)	60 (18)	80 (24)	100 (30)	125 (38)	150 (45)	175 (53)	200 (60)	225 (68)	250 (76)	275 (83)	300 (91)	325 (99)	350 (106)		
ET5M	GPM (LPS)	3.1 (.19)	3.0 (.18)	2.9 (.18)	2.8 (.17)	2.7 (.17)	2.6 (.16)	2.4 (.15)	2.3 (.14)	2.2 (.13)	2.1 (.13)	2.0 (.12)	1.9 (.11)	1.8 (.11)		1.7 (.10)				
	BHP	.40	.43	.45	.48	.50	.51	.55	.57	.59	.63	.71	.78	.86		.94				
	Motor Size	1/2 HP					3/4 HP					1 HP								
ET6M	GPM (LPS)	4.8 (.30)	4.6 (.29)	4.3 (.27)	4.1 (.25)		3.8 (.23)	3.6 (.22)	3.4 (.21)	3.2 (.20)	3.1 (.19)	3.0 (.18)	2.9 (.18)	2.8 (.17)		2.7 (.17)				
	BHP	.50	.50	.50	.54		.60	.66	.73	.80	.83	.88	.92	.96		1.0				
	Motor Size	1/2 HP			3/4 HP					1 HP										
ET7M	GPM (LPS)	6.6 (.41)	6.4 (.40)	6.2 (.39)	5.9 (.37)	5.8 (.36)	5.5 (.34)	5.2 (.32)	4.9 (.30)	4.6 (.29)	4.5 (.28)	4.3 (.27)	4.1 (.25)		3.9 (.24)	3.8 (.23)	3.7 (.23)	3.6 (.22)		
	BHP	.65	.65	.66	.67	.67	.68	.75	.78	.83	.89	1.0	1.10		1.26	1.29	1.33	1.40		
	Motor Size	3/4 HP						1 HP				1 1/2 HP								



NOTE: When pumping hot water over 180°F (82.2°C), check the NPSH available in the pumping system against the required pump NPSH shown on pump performance curves. Available NPSH must be greater than required NPSH.

Base Mounted Turbine Pumps

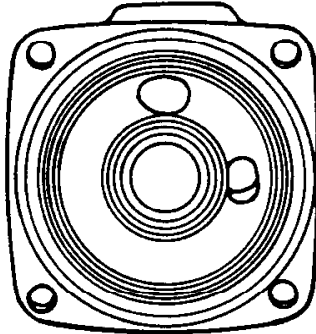
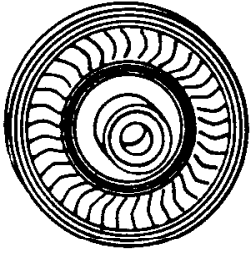

BURKS Series ET turbine pumps are available for capacities up to 8 g.p.m. (0.50 l.p.s.) - pressures up to 150 p.s.i. (1034 kPa) and temperatures up to 225°F. (107°C), with standard mechanical shaft seal. Special shaft seals are available for higher temperatures and fluids other than water.

These compact turbine pumps are designed for pumping clear water and many other non-abrasive, lower viscosity liquids. They are especially engineered for boiler feed on steam process applications and will serve up to a 38 hp. boiler at a 3 to 1 safety factor. Available in bronze fitted as standard. All bronze or stainless steel construction also available. These pumps are recommended for many application requiring higher pressures and lower capacities.

Coupling guard furnished on all complete Base-Mounted units manufactured by Burks Pumps. Not furnished with purchase of pump only, but required.

BURKS is the only turbine pump with Life-Lok® external Impeller adjustment feature that allows readjustment of impeller without disturbing piping, disassembling pump or replacing parts. Gives up to 40% longer service life than turbine pumps of other designs.

MAXIMUM OPERATING CONDITIONS	
TEMPERATURE (For Standard Buna-N Seal)	225°F (107°C)
INLET PRESSURE	100 PSI (689kPa)
CASING WORKING PRESSURE	250 PSI (1723kPa)

FOR TEMPERATURES TO 500°F (260°C)

Series ET Pumps are available in a Jacketed Seal Cavity design for pumping hot oil, hot water and heat transfer fluids in common use in high temperature heating or cooling applications. This feature greatly extends seal life in high temperature applications. To order, add suffix "J" to pump catalog number for temperatures below 400°F (204°C) and add suffix "JK" to pump catalog number for temperatures over 400°F (204°C). *Example: ET6MJ.* See Section on High Temperature Pumps for more information.

MATERIALS OF CONSTRUCTION			
PART	BRONZE FITTED	ALL BRONZE	STAINLESS STEEL
Frame	Cast Iron	Bronze	#303 Stainless
Impeller	Bronze (Monel Blades)	Bronze (Monel Blades)	#303 Stainless
Raceway	Bronze	Bronze	#303 Stainless
Shaft	#303 Stainless	#303 Stainless	#303 Stainless
Shaft Seal	Carbon-Ceramic SS - Buna-N	Carbon-Ceramic SS - Buna-N	Carbon-Ceramic SS - Buna-N

Base Mounted Turbine Pumps

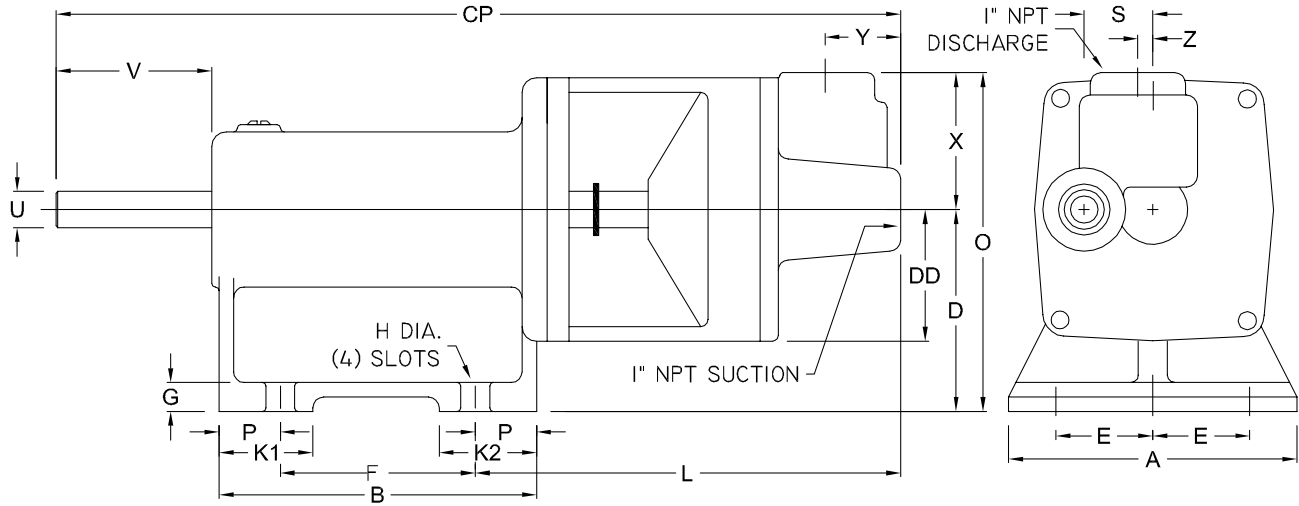

DIMENSIONS IN INCHES (mm)																						
A	B	CP	CP (S.S.)	D	DD	E	F	G	H	K1	K2	L	L (S.S.)	O	P	S	U	V	X	Y	Y (S.S.)	Z
5 (127)	5½ (139)	14¼ (361)	14½ (368)	3½ (88)	2¼ (57)	2 (50)	3⅞ (85)	½ (13)	½ (13)	1⅝ (41)	1⅞ (42)	7⅞ (187)	7⅞ (193)	5⅞ (149)	1⅞ (27)	1⅜ (30)	⅝ (15)	2¼ (57)	2⅝ (60)	1⅞ (33)	1 (25)	⅜ (4.7)

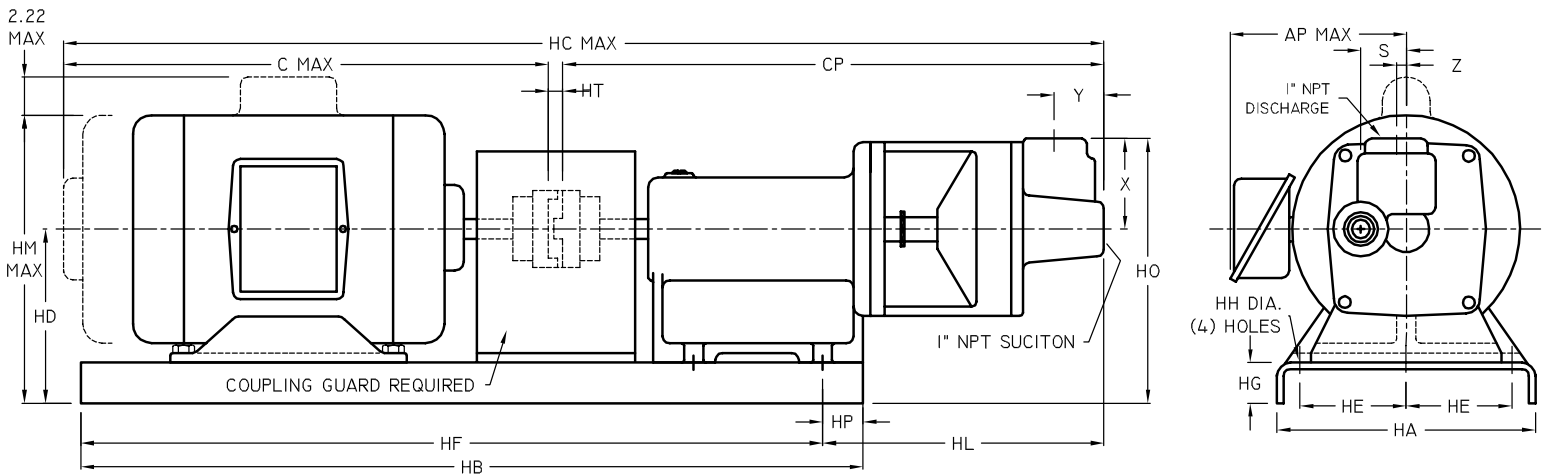

DIMENSIONS IN INCHES (mm)																								
Motor Frame	AB	C	CP	CP (S.S.)	HA	HB	HC	HC (S.S.)	HD	HE	HF	HG	HH	HL	HL (S.S.)	HM	HO	HP	HT	S	X	Y	Y (S.S.)	Z
56	---	12½ (317)	14¼ (361)	14½ (368)	8 (203)	22 (558)	27¼ (692)	27½ (698)	6 (152)	3 (76)	20 (508)	2½ (63)	1⅞ (17)	7⅞ (185)	7⅞ (192)	9⅞ (233)	8⅞ (212)	1 (25)	½ (12)	1⅞ (30)	2⅝ (60)	1⅞ (33)	1 (25)	⅜ (4.7)
143T	8⅞ (227)	10⅞ (271)	14¼ (361)	14½ (368)	8 (203)	22 (558)	25⅞ (646)	25⅞ (652)	6 (152)	3 (76)	20 (508)	2½ (63)	1⅞ (17)	7⅞ (185)	7⅞ (192)	9½ (241)	8⅞ (212)	1 (25)	½ (12)	1⅞ (30)	2⅝ (60)	1⅞ (33)	1 (25)	⅜ (4.7)
145T	8⅞ (227)	11⅞ (296)	14¼ (361)	14½ (368)	8 (203)	22 (558)	26⅞ (671)	26⅞ (677)	6 (152)	3 (76)	20 (508)	2½ (63)	1⅞ (17)	7⅞ (185)	7⅞ (192)	9½ (241)	8⅞ (212)	1 (25)	½ (12)	1⅞ (30)	2⅝ (60)	1⅞ (33)	1 (25)	⅜ (4.7)

A strainer, approximately 20 mesh, should be installed on the suction side of the pump to prevent chips, scale or hard foreign particales from entering the pump and damaging the raceway and impeller.

Base Mounted Turbine Pumps

SERIES ET5 & ET5M

LIQUID: 1.0 SP. GR.
 IMPELLER: SA-9524-5
 RACEWAY: 9525-5
 SIZE: 1 x 1

3450
RPM



10930-1

Base Mounted Turbine Pumps

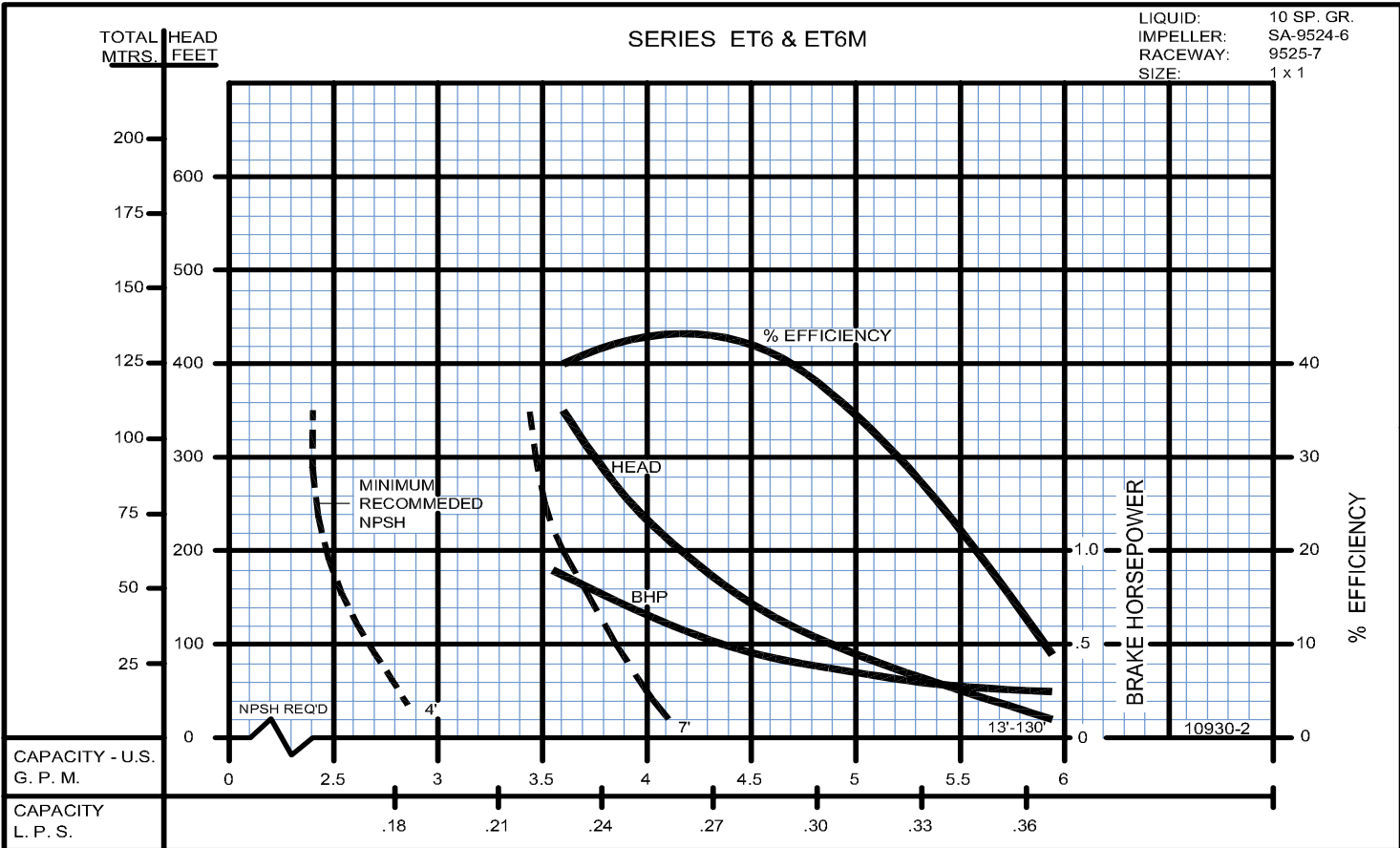
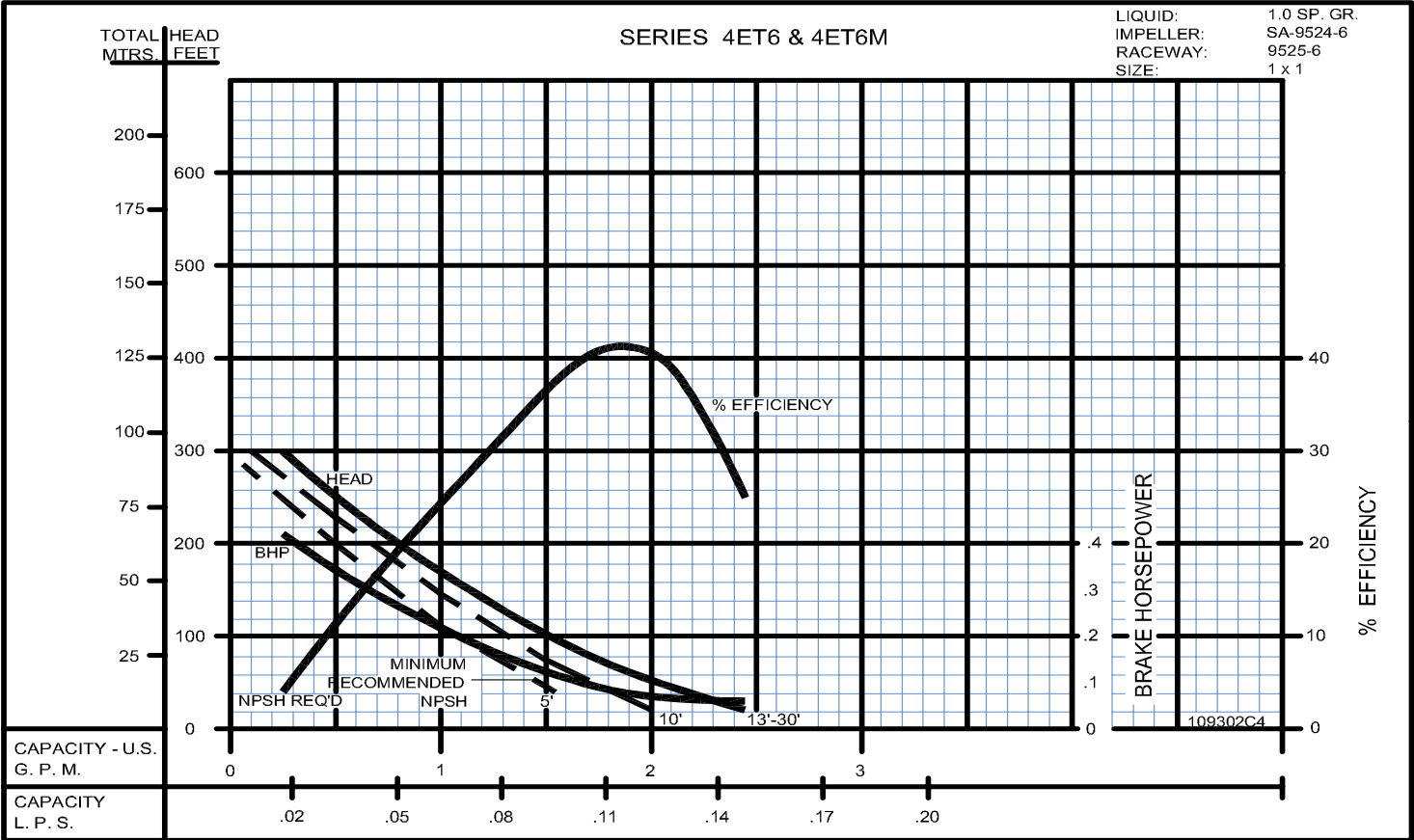

Base Mounted Turbine Pumps

1725 RPM

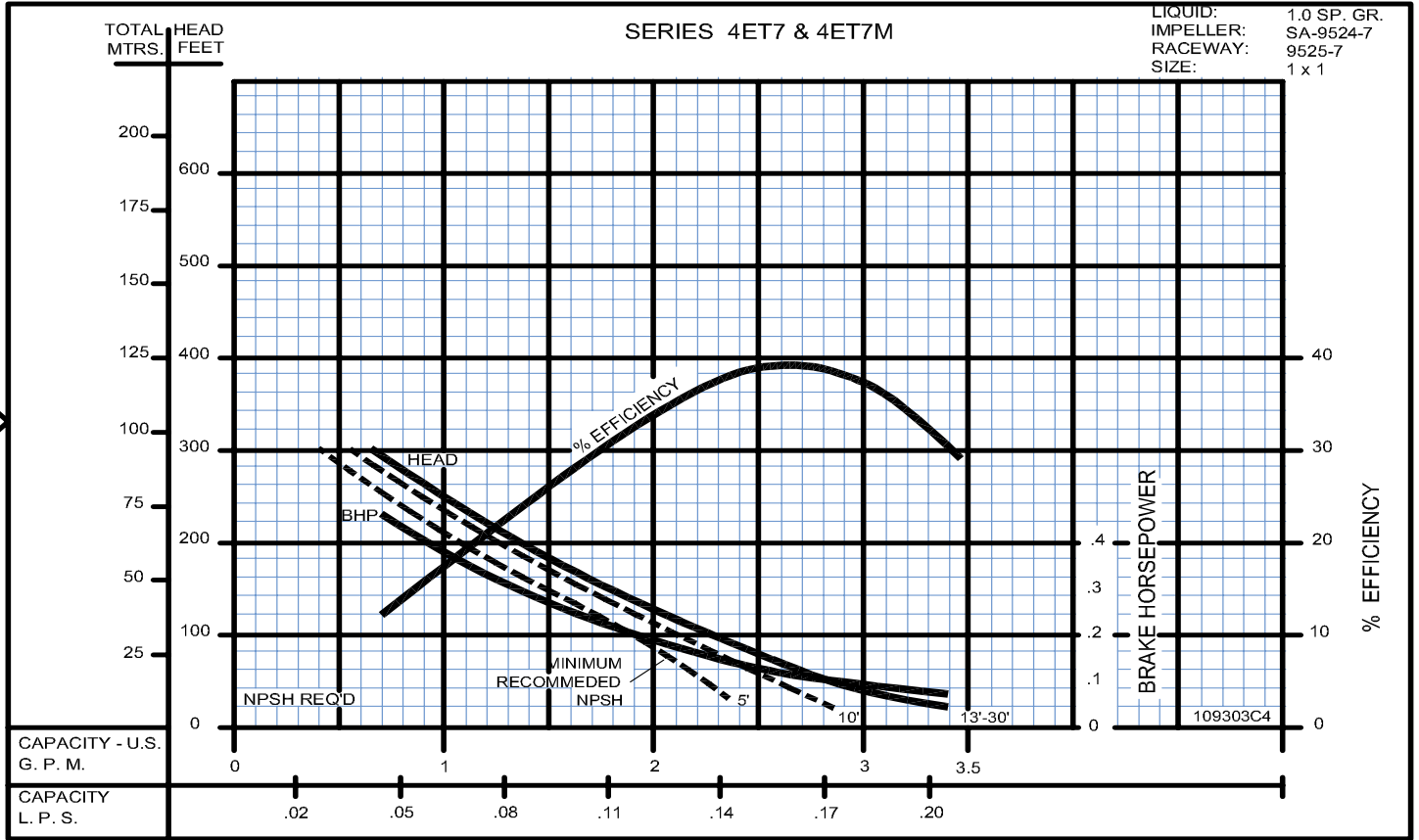

3450 RPM

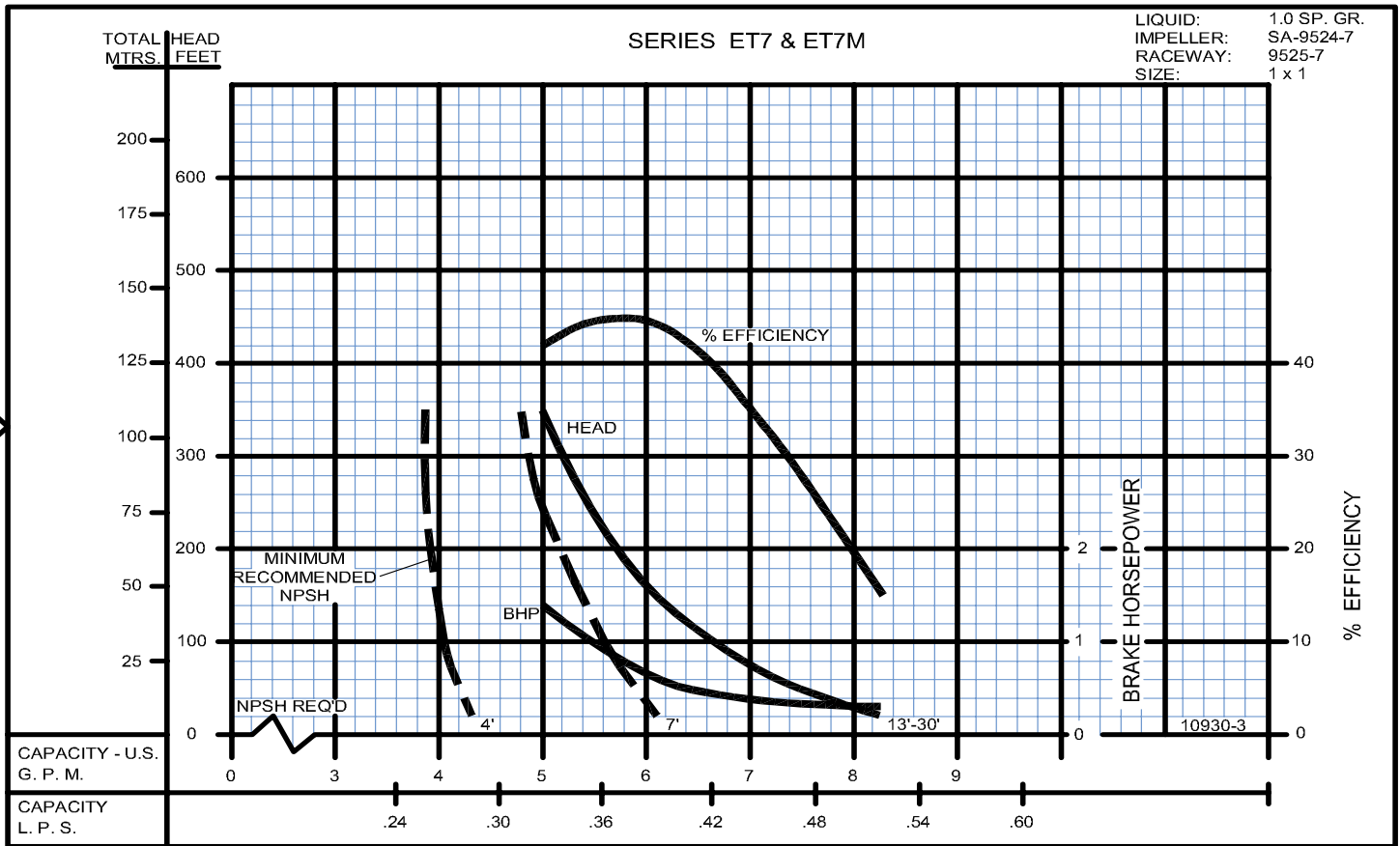

Base Mounted Turbine Pumps

SERIES ET8 & ET8M

LIQUID: 1.0 SP. GR.
 IMPELLER: SA-9524-8
 RACEWAY: 9525-8
 SIZE: 1 x 1 1/4

TOTAL HEAD
 MTRS. FEET

200
600
175
500
150
125
400
100
300
75
200
50
100
25
0

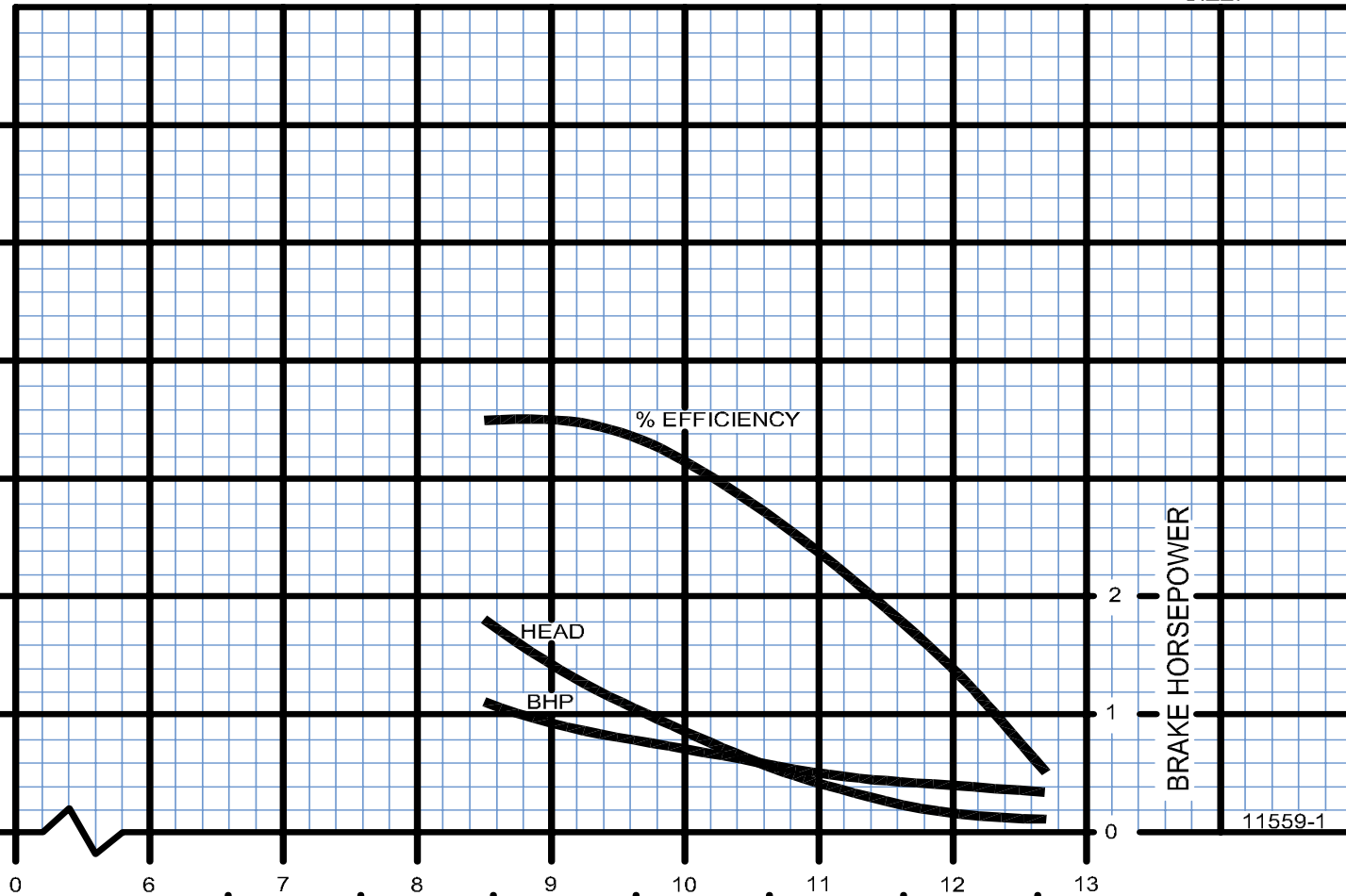

CAPACITY - U.S.
 G. P. M.

CAPACITY
 L. P. S.

BRAKE HORSEPOWER

% EFFICIENCY

3450
 RPM

11559-1